

CHAMBERS WHARF COMMUNITY LIAISON WORKING GROUP



Tideway

5 June 2023
Chair – Patricia Brown

Content

Topic	Lead
Welcome, introductions and apologies	Patricia Brown
Notes and actions from last meeting	Patricia Brown
Updates from project team <ul style="list-style-type: none">• Construction update and future programme• Trigger Action Plan removal• Noise and air quality update• Mitigation• Community Investment and Community Relations	Tideway team Luke Rees Allen Summerskill Matthew Gardiner Emily Black Martin Griffiths
Southwark Council Community Enhancement Fund and Section 106 updates	Southwark Council Jacqueline Christie
Feedback and discussion	All
Any other business	All

Open actions from previous meetings			
Meeting	Action	Responsibility	Status
21 Nov	CVB to review how they are communicating piling installation and cofferdam removal with residents.	CVB	Open – further information sheets for impacted residents are planned for cofferdam removal. We have used the weekly e-newsletters to provide greater detail for the piling works.
21 Nov	CVB to provide greater clarification of the expected impact of cofferdam removal at next meeting.	CVB	Open – this will start to be covered from today's slides onwards
21 Nov	Future developer to be invited to CLWG meeting at appropriate time.	Tideway	Open – developer to be invited in due course
4 July	Team to present at future CLWG on the reused and recycled elements of the project.	CVB	Open and ongoing – team will continue to highlight where we have reused and recycled elements of the project. There will be a more detailed presentation made in due course.
Closed actions from previous meetings			
21 Nov	Tideway to follow up with Southwark Council regarding sharing Southwark's update on the Section 106 projects and Community Enhancement Fund	Tideway / Southwark	Closed – updates from Southwark Council distributed regularly via weekly e-newsletter Presentation will be covered in today's slides
21 Nov	CVB to provide greater clarification of the expected impact of piling, using any comparison from other sites if available.	CVB	Closed – CVB have used the weekly e-newsletters to provide greater detail of piling works including comparable information of earlier site activity
21 Nov	Tideway to speak with Chief Executive Andy Mitchell regarding the Standard Case procedure and the 10 April 2017 meeting and confirm back to resident.	Tideway	Closed - Tideway Chief Executive has responded to resident on the matter.
21 Nov	Tideway to provide details of the Independent Compensation Panel	Tideway	Closed – details provided with previous meeting notes, weekly e-newsletter & included in today's slides
21 Nov	Tideway to provide a summary note with planning dates for the river wall alignment submission and the upcoming flats submission	Tideway	Closed - details provided with previous meeting notes
21 Nov	Tideway to provide link to Tideway's Tunnel Vision episode that shows the story of habitat creation.	Tideway	Closed - details provided with meeting notes

CONSTRUCTION UPDATE



Tideway

Luke Rees, Project Manager

GREENWICH TUNNEL SECONDARY LINING PROGRESS

- Secondary lining of Greenwich connection tunnel
- Shutters have progressed through $\frac{3}{4}$ of tunnel
- 9,750m³ of concrete poured to date
- Team is working 24/5



SURFACE PROGRESS



June 2022



February 2023

WORKS COMPLETED NOVEMBER 2022 – JUNE 2023



Air Treatment Unit (ATU) archaeological excavation complete

Air Treatment Unit structural concrete works commenced

East side piling completed 20 piles installed

East side tie-in detail works started



Removal of Slurry Treatment Plant and concrete tanks completed

Construction of large pre-cast slab cover beams started

West side piling 61 piles installed

Capping beam excavation started

Lunar house 3 piles completed.

Muck away by barge

Aggregate deliveries for secondary lining and logistics

WORKS COMPLETED RIVER WALL AND PILING EAST AND WEST



Guide wall construction

WORKS COMPLETED RIVER WALL PILING

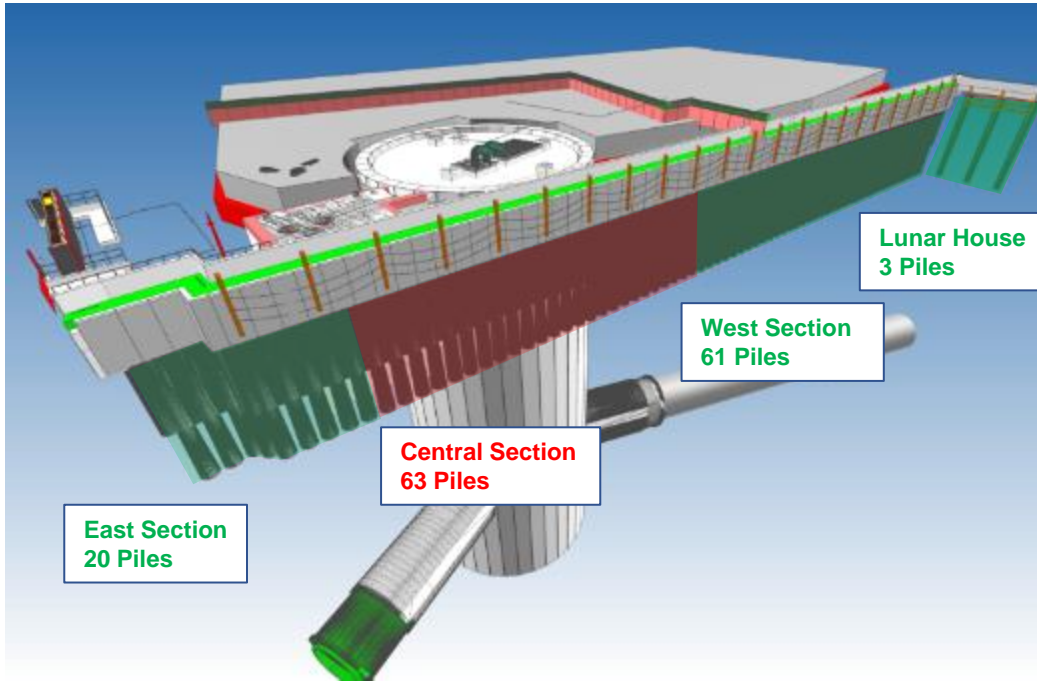

- East section 20 piles installed
- West section 61 piles installed
- Lunar house piles installed
- 5,000t of material excavated and removed by barge

WORKS COMPLETED AIR TREATMENT UNIT ARCHAEOLOGICAL EXCAVATION

- MOLA Team – 8 archaeologists on site for 6 weeks
- Exposed 18th century river wall, constructed of curved ships timbers
- Uncovered hollowed timber drainage pipe
- Pub token dated 1667
- Halfpenny from reign of George 1st 1714-1727



WORKS PLANNED JUNE 2023 TO DEC 2023

Air Treatment Unit construction

- Works started; currently constructing reinforced concrete walls
- Structure will complete August 2023
- MEICA (Mechanical, Electrical, Instrumentation, Control and Automation works) will start in Sept 2023

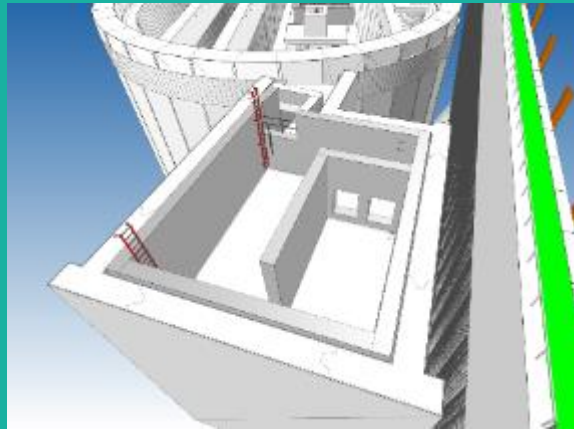

East tie-in detail

- Works started; excavated to depth with obstructions removed
- Currently carrying out a series of concrete pours
- These works will complete in June 2023

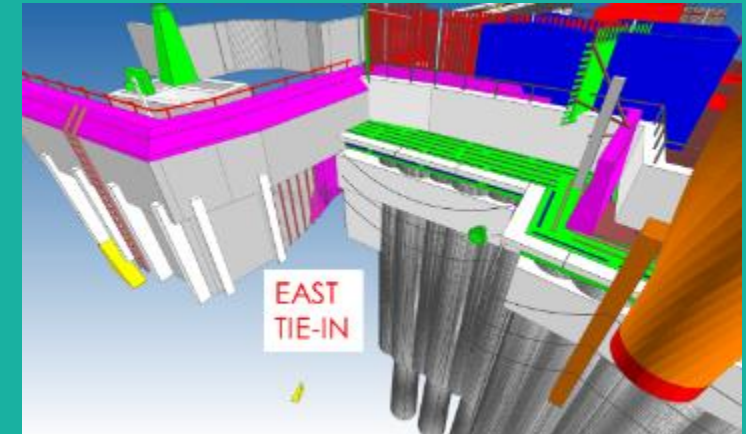

WORKS PLANNED JUNE 2023 TO DEC 2023

Kiosk Construction

Works will begin in Aug 2023 and include

- Ducting and drainage installation
- Concrete works for small retaining walls and sl

- Hoarding move will taking place during construction
- Kiosk building construction



- - - - - Existing 5m hoarding
- - - - - Garden Wall

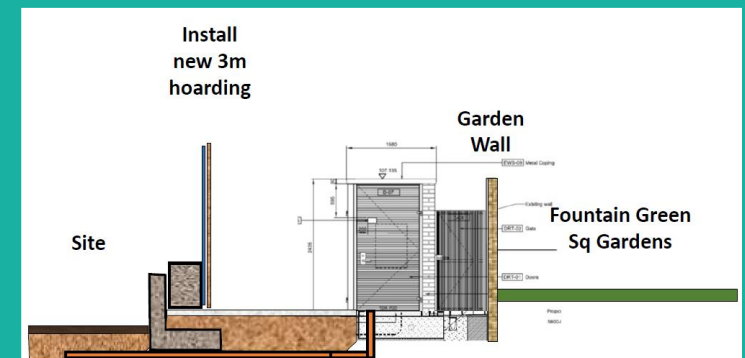
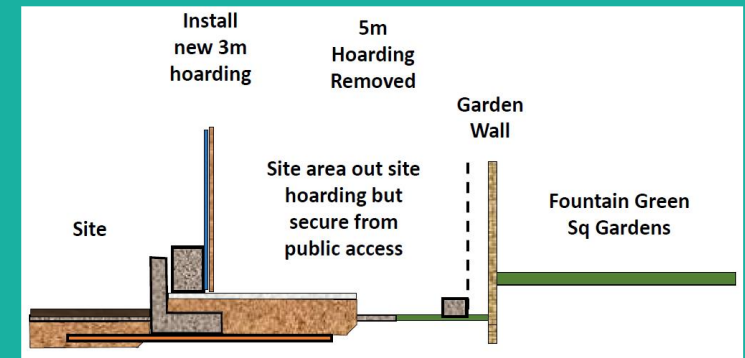
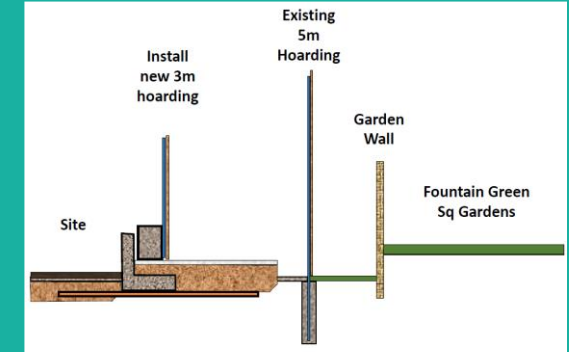

WORKS PLANNED JUNE 2023 TO DEC 2023

West tie-in detail

The west tie detail works will start in June 2023.

We will saw cut, excavate, remove obstructions and install temporary support sheets. We will then cast the concrete tie in detail in a series of concrete pours, remove the sheets and back fill.

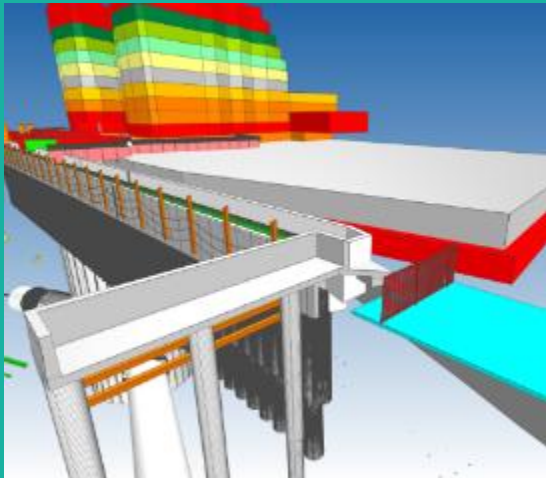

Capping beam installation

These works will begin in June 2023 in the west section and then move to the east. The work involves breaking a section of the existing slab and excavating to depth. We will then crop the river wall piles, fix steel reinforcement, install shutters and cast the wall in a series of concrete pours.

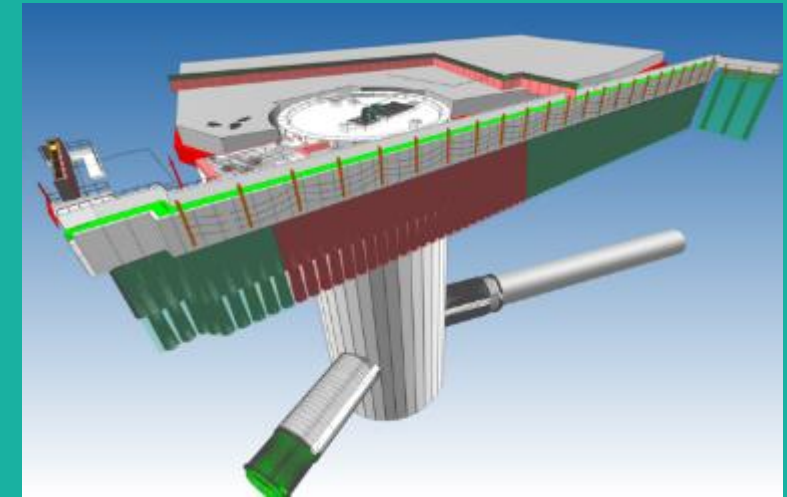
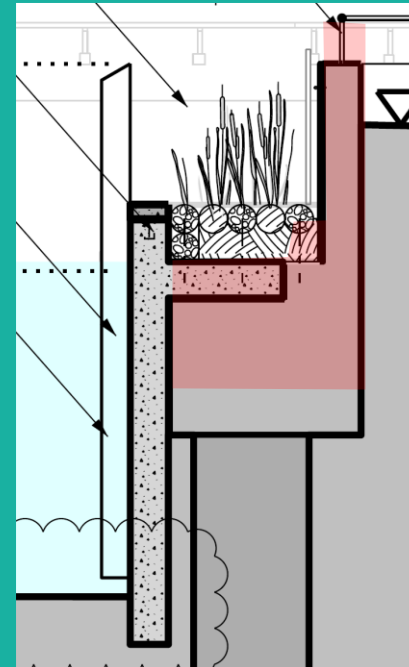

WORKS PLANNED JUNE 2023 TO DEC 2023

Pre-cast slab cover beam construction

- 5 precast beams are required to cover the Chambers Wharf shaft. Works have started.
- The beams will be constructed on the west side of the acoustic shed where the Slurry Treatment Plant was located.
- The beams weigh between 70t and 175t.
- Works will include shuttering, steel fixing and pouring concrete. A crawler crane and concrete pump will be used as part of these works.
- The beams will then be lifted into position in April 2024.



Completion of secondary lining and shaft strip out

- Once the secondary lining shutters reach the Chambers Wharf shaft they will be removed to surface, dismantled & leave site.
- Secondary lining equipment will then be removed from pit bottom and taken off site.
- Secondary lining equipment will to leave site from August 23.



UPCOMING PROGRAMME OF WORKS



	June	July	August	September	October	November	December
East Side Tie-in Detail	Green						
ATU Structural Works	Orange	Orange	Orange				
Kiosk Construction			Green	Green	Green	Green	Green
West Side Tie-in Detail	Orange	Orange					
Capping Beam Construction	Green	Green	Green				
Pre-cast Beam Construction	Orange	Orange	Orange	Orange	Orange		
Secondary Lining	Green	Green	Green				
Shaft Strip Out				Orange	Orange	Orange	
Shaft Benching						Green	Green

HIGH LEVEL PROGRAMME OF WORKS



Activity	Date	2023				2024				2025			
		Q1	Q2	Q3	Q4	Q1	Q2	Q3	Q4	Q1	Q2	Q3	Q4
Complete Greenwich Tunnel Secondary Lining	Oct-23			◆									
Complete Acoustic shed removed	May-24					◆							
Complete final section of river wall piling	Jun-24						◆						
Start cofferdam removal	Aug-24							◆					
Finish cofferdam removal	Apr-25									◆			
Complete CHAWF Civils works	May-25										◆		
Vacate CHAWF Site	May-25										◆		

COFFERDAM REMOVAL METHODOLOGY

Removal of Cofferdam – Summer 2024 to Spring 2025

- The cofferdam will be removed in the reverse sequence of how it was installed.
- The hinterland and fill will be removed using excavators and material removed by barge.
- The cells will then be excavated and sheets removed in a sequence working from east to west.
- The majority of the sheet piles will be removed using a GIKEN silent piler. The remaining piles that cannot be removed using the GIKEN will be removed using a vibro hammer.



REMOVAL OF SECONDARY GLAZING, BALCONY SCREENS & VENTILATION



We are currently in the process of writing to members of the local community who had secondary glazing, balcony screens or ventilation systems installed.

The letters contain a form where properties can request to have these items removed at a date in the future or left in place after the Tideway works at Chambers Wharf are completed - which will provide further protection for the subsequent residential development.

The forms need to be returned to “FREEPOST Tideway”

Allen Summerskill, Stakeholder and Consents Manager

OFFICIAL

Trigger Action Plan – Noise Insulation Package Retention / Removal Acceptance Form.

Property Address:

Name:

Contact Number:

Email Address:

I have received the following:

Secondary Glazing
Mechanical Ventilation
Balcony Screen

My preference is (mark where appropriate):

	I would like this removed	I would like to retain this
Secondary Glazing	<input type="checkbox"/>	<input type="checkbox"/>
Mechanical Ventilation	<input type="checkbox"/>	<input type="checkbox"/>
Balcony Screen	<input type="checkbox"/>	<input type="checkbox"/>

I confirm that I accept the proposals above and as detailed in the attached letter.

Signature.....
Name.....
Date.....

Please tick as appropriate:
(Please note that if you are a tenant, we will also need consent from the owner).

Tenant
 Owner
 Property Manager
 Other, please specify

Please return this completed form to “FREEPOST Tideway”. Thank you.

CHAMBERS WHARF



Proposed future development by others will follow once the Tideway project is complete.



NOISE AND AIR QUALITY

Matthew Gardiner, Environment Manager

Environment Summary: Nov 22 – May 23



Noise Monitoring since last CLWG

- No Section 61 noise exceedances in the last 6 months

Air Quality Monitoring

- No air quality exceedances in the last 6 months (24h PM10)

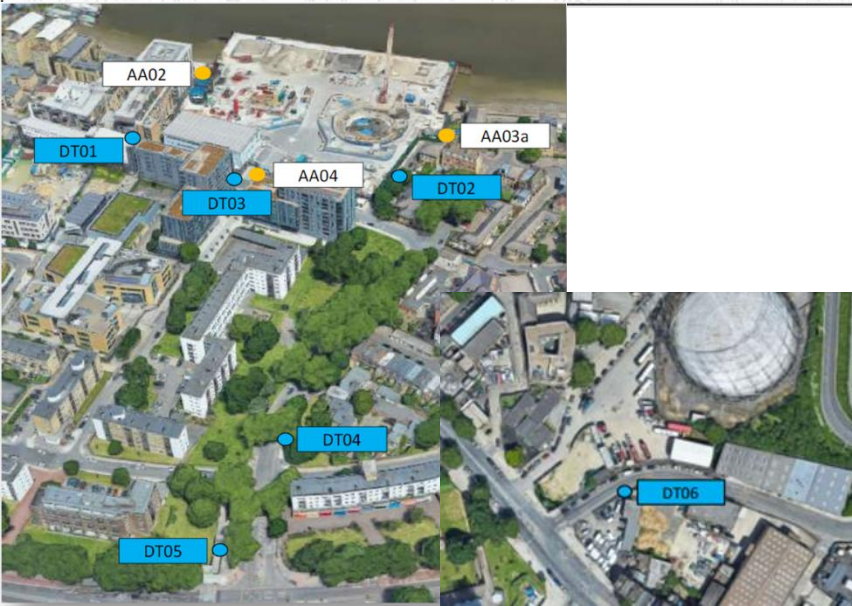

Any exceedances shown by our monitors are investigated thoroughly after we are alerted.

**MITIGATION
AND
CONTACT US**

Emily Black, Engagement Manager

MITIGATION - making a claim if affected by Tideway's work



Who do I go to for advice?

For personal assistance contact our Helpdesk: 08000 30 80 80 or helpdesk@tideway.london

For independent advice contact Independent Advisory Service (IAS) Helpline: 0800 917 8845 or info@tidewayias.co.uk

How do I submit my form?

The Helpdesk can submit your form to the Independent Compensation Panel (ICP) on your behalf, or you can submit your form directly to the ICP: admin@tidewayicp.london

You can download the claim form from the Tideway website:

www.tideway.london/help-advice/compensation-information/Independent-Compensation-Panel

CONTACT US



- If you do have any questions or enquiries, please contact the Tideway Helpdesk:
- Telephone: **0800 030 80 80**
- Email: **Helpdesk@Tideway.London**

COMMUNITY INVESTMENT AND LEGACY

Martin Griffiths, Senior Community Relations Manager

LEGACY: STEM & ENVIRONMENT



Career Ready in December



Tideway again hosted 'A Capital Experience' for charity Career Ready. More than 40 students from secondary schools visited our Chambers Wharf offices



Volunteering for Thames 21 citizen science survey and clear up



Site team volunteers cleaned a community garden in November. The garden representative said 'I couldn't have been more pleased'. Tideway have been supporting numerous 'green' London projects.



CVB shortlisted for Water Industry awards in category: *Net Zero Carbon Initiative* with Tideway East Fuel Efficiencies



LEGACY: STEM



SKILLS FOR LIFE

Apprenticeships
National Apprenticeship Week
6th to 12th February 2023



Tideway CVB continues staff support for STEM (science, technology, engineering, mathematics) Providing Interview preparatory skills, CV building, careers advice and mentoring at London Design & Engineering University Technical College. Staff continuing mentoring for Construction Youth Trust.



London Youth Rowers Life Skills Day



Employability sessions at Langdon Park School



CHAMBERS WHARF COMMUNITY ENHANCEMENT FUND & SECTION 106

Jacqueline Christie

Project officer

June 2023



Framework

Under legal agreement Thames Water have agreed to fund a number of projects in the local area surrounding the Chambers Wharf site. This is set out in with accordance with the details and terms in the agreement.

Key points

- Financial contributions to local infrastructure projects in the area adjacent to Chambers Wharf including local schools, play facilities, transport improvements.
- Terms of reference for the establishment of a Community Liaison Working Group (CLWG) for local residents to find out the latest information and to raise questions and any concerns.
- Terms of reference for the expenditure of a £1m Community Enhancement Fund (CEF) with clear guidance on how local people can submit project ideas, and a how a local panel of stakeholders can oversee the expenditure.
- A set of obligations on the contractor to create local employment and skills outcomes for residents in Southwark.

Section 106 & Community Enhancement Fund Breakdown

- The Unilateral Undertaking signed in 2014 secured approximately an indexed-linked £5,385,000 which has been allocated and being spent on local infrastructure projects.
- The community enhancement fund is £1,000,000 payable annually over 7 years.
- The community enhancement fund has **£429,975.00** remaining to spend on local community projects.

Section 106 Project

George Row Playground Development

Work was completed on the George Row playground in December 2023.
The full cost for the project was £420,000



Before image

Section 106

George Row Playground Aerial View



Section 106

George Row Play Equipment



Section 106

George Row Playground Seating & Planting



Current Section 106 work

Designs are progressing for the redevelopment of the next phase of children's play. This phase will cover:

- Scott Lidgett Playground
- Wickfield play area

Once the designs are agreed they will go out for final consultation

CEF Project

Wilson Grove Planting Project

Southwark Groundwork maintenance team along side Wilson Grove residents completed the planting project in December and is now in full bloom.



CEF Project

Wrayburn TMO Bike Sheds

Wrayburn TMO want to encourage more people to cycle with the new cycle path being open along the main road it has made people feel a lot safer and more confident. The bike users now have a safe and secure place to keep their bikes.



CEF Project

Schools Out @ Salmon Project

The Community Enhancement Fund funded the Salmon Youth Centre in Bermondsey to provide allocated places to Chambers Wharf children providing a total of 304 young people with a really exciting summer of activities with a 1 weekly play scheme, 17 trips, 3 evening clubs and 1 residential.

707 attended throughout the week (116 females and 121 males). They took young people out on trips each day with 17 trips taking place. Young people had the opportunity to visit inflatable parks, bowling, cinema, and several local parks and complete a host of activities.

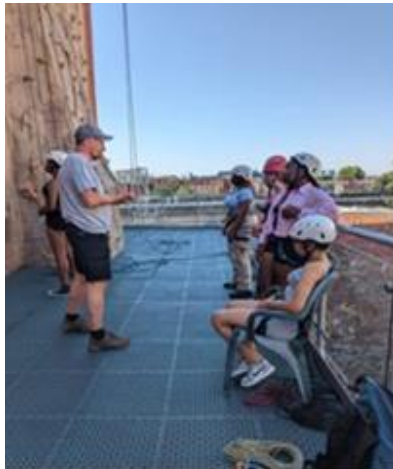

Young Peoples Feedback

“the Salmon Summer scheme was my favourite week of the summer the rest of the summer was really boring, I didn’t go anywhere I stayed in my house” 11 year old.

CEF Project

Dickens Estate Hedging Project

A planting day was held on Saturday 10th December 2022 just before the heavy snow came. The mix of native plants evergreen, supports pollinators (bee-friendly). This project also includes 3 years maintenance of the hedges covering all 10 blocks on the Dickens Estate and along Jamaica Road costing £63,000.00.



As well as noise reducing, the hedging captures pollution, and will improve and soften the aesthetic of dense urban environment.

The evergreen plant selection will liven up and add colour to the area.

Community Enhancement Fund Voting Event 7 – February 2023

As of February 2023, **£429,975.00** remains unallocated of the overall fund of £1 million

In the most recent round of submissions (February 2023) 7 projects were successful in their application for funding:

- Yes make Community Green space
- A Wildlife Walkway Project
- Defibrillator for Old Justice Pub
- Wrayburn TMO Ecology projects
- Downside Youth Center Parent & toddler Group and Zero to Hero Project
- DETRA Coronation Party

The next deadline for applications is 31 August 2023

Community Enhancement Fund

Years	Number of Projects	Total
2017	7	£78,100.00
2018	3	£57,400.00
2019	6	£134,824.00
2020	6	£22,995.00
2021	6	£49,012.00
2022	5	£120,112.00
2023	7	£107,582.00
Total	47	£570,025.00
Balance		£429,975.00

Improvements 2022-23

Applications

- All applications will now complete a survey.

Community Enhancement Fund presentation meetings

- Panel members can have the option to attend the presentation meeting online. This will be dependant on the venue's facilities.

Engagement strategy

- Publicity was successfully completed to recruit new panel members (3 new panel members recruited to represent the local community)
- Planned visits to funded projects to see projects in place

How to get involved

- Residents with community improvement ideas are encouraged to work together to make an application to the Community Enhancement Fund
- Full details and the application form are available on Southwark Council's website at <https://www.southwark.gov.uk/tideway>
- To apply or for further information email jacqueline.christie@southwark.gov.uk